

Right Angle Collet Grinders

1.2 H.P. (900 W)

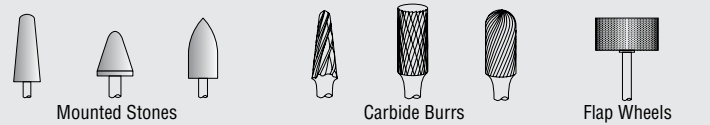

Air Inlet Size: 3/8" NPT
Hose Size Recommendations: 1/2" (12.7 mm)
Extra Charge Accessories

- Safety Lever • Rear Exhaust
- Standard Equipment**
- Tool • Operating Instructions and Service Manual
- 2 Wrenches (sizes based on options)

Quick Order Number				
Model Number	Collet Size	Maximum Operating Speed	Case Material	
			Aluminum	Steel
400RAED	1/4 Inch	10000 RPM	400RAED;1/4	400RAEDS;1/4
410RAED		13000 RPM	410RAED;1/4	410RAEDS;1/4

All the versions listed in the table will be supplied with a standard lever throttle (class 1). A safety lever throttle (class 2) is also available.

This chart has been provided as a means to quickly identify a particular tool. The ordering numbers listed represent the most common versions of our tools. If more specialized versions are required, please build your model number per the following model number flow chart.

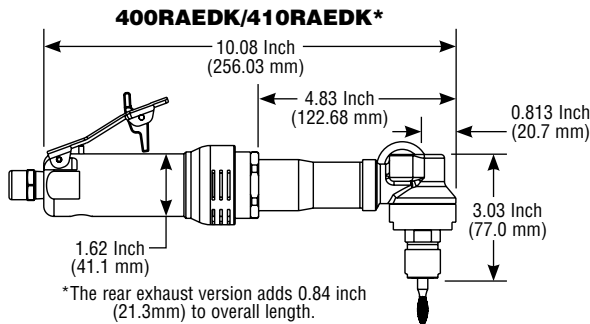

HP 1.2 H.P. (900 W)

Lbs 2.8 Lb. (1.3 Kg) Aluminum
3.5 Lb. (1.6 Kg) Steel

cfm 35 cfm (16.5 L/s) Max

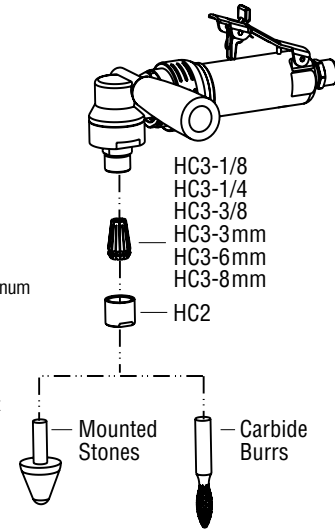

Example Model Number: **400RAED K S R ; 10000 ; 1/4**

Model Number	Lever Style	Case Material	Exhaust Direction	Operating Speed	Collet Size
400RAED	Please choose one of the following options: No Designation - Standard Lever K - Safety Lever	Please choose one of the following options: No Designation - Aluminum Case S - Steel Case	Please choose one of the following options: No Designation - Side Exhaust R - Rear Exhaust	10000 - 10000 R.P.M.	Please choose one of the following options: 1/8 - 1/8 Inch Collet 1/4 - 1/4 Inch Collet 3/8 - 3/8 Inch Collet 3MM - 3mm Collet 6MM - 6mm Collet 8MM - 8mm Collet
410RAED				13000 - 13000 R.P.M.	

Geared Tool

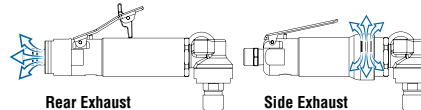

WARNING: Follow all recommendations from component and abrasive manufacturers for speeds and proper usage.