

Right Angle Collet Grinders

0.4 H.P. – 0.7 H.P. (300 – 525 W)

280RADS/290RADS/
330RADS/340RADS



280RADK/290RADK/
330RADK/340RADK



Air Inlet Size: 1/4" NPT (1/4" BSP Available)
Hose Size Recommendations: 3/8" (10 mm)
Extra Charge Accessories

- Safety Lever
- Standard Equipment**
- Tool • Operating Instructions and Service Manual
- 2 Wrenches (sizes based on options)

Quick Order Number

Model Number	Collet Size	Maximum Operating Speed	Case Material	
			Aluminum	Steel
280RAD	1/4 Inch	16000 RPM	280RAD;1/4	280RADS;1/4
290RAD		26000 RPM	290RAD;1/4	290RADS;1/4
330RAD		12000 RPM	330RAD;1/4	330RADS;1/4
340RAD		20000 RPM	340RAD;1/4	340RADS;1/4

All the versions listed in the table will be supplied with a standard lever throttle (class 1). A safety lever throttle (class 2) is also available.

This chart has been provided as a means to quickly identify a particular tool. The ordering numbers listed represent the most common versions of our tools. If more specialized versions are required, please build your model number per the following model number flow chart.

280RADK/290RADK/330RADK/340RADK

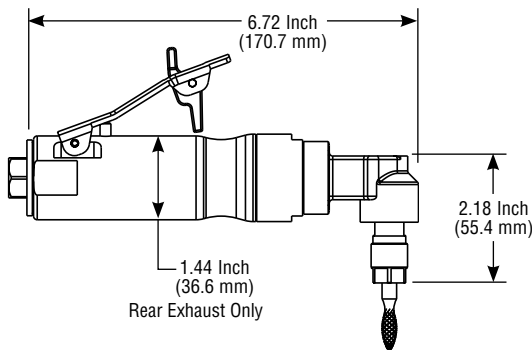

HP 280RAD/290RAD - 0.4 H.P. (300 W)
330RAD/340RAD - 0.7 H.P. (525 W)

Lbs *Aluminum Steel*
280RAD - 1.3 Lbs. (0.6 Kg) 1.8 Lbs. (0.8 Kg)
290RAD - 1.3 Lbs. (0.6 Kg) 1.8 Lbs. (0.8 Kg)
330RAD - 1.4 Lbs. (0.6 Kg) 2.0 Lbs. (0.9 Kg)
340RAD - 1.4 Lbs. (0.6 Kg) 2.0 Lbs. (0.9 Kg)

cfm 330RAD/340RAD - 18 cfm (8.5 L/s)
330RAD/340RAD - 25 cfm (11.8 L/s)

Example Model Number: **280RAD K S ; 16000 ; 1/4**

The blue highlighted entries are shown in the Quick Reference Box above.

Model Number	Lever Style	Case Material	Operating Speed	Collet Size
280RAD	Please choose one of the following options: No Designation - Standard Lever K - Safety Lever	Please choose one of the following options: No Designation - Aluminum Case S - Steel Case	16000 - 16000 R.P.M.	Please choose one of the following options: 1/8 - 1/8 Inch Collet 1/4 - 1/4 Inch Collet 3MM - 3mm Collet 6MM - 6mm Collet
290RAD			26000 - 26000 R.P.M.	
330RAD			12000 - 12000 R.P.M.	
340RAD			20000 - 20000 R.P.M.	

Geared Tool



WARNING: Follow all recommendations from component and abrasive manufacturers for speeds and proper usage.

RIGHT ANGLE GRINDERS

The ER Heavy Duty Collet Is Available On 280RAD/290RAD & 330RAD/340RAD Series



Front view of 280RAD/290RAD/330RAD/340RAD Series Tools