

## Chipping Hammers

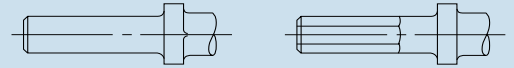

CHIPPING HAMMERS



**Air Inlet Size: 1/4" NPT**  
**Hose Size Recommendations: 3/8" (10 mm)**  
**Extra Charge Accessories**

- Safety Lever
- Standard Equipment**
- Tool • Operating Instructions and Service Manual

### Quick Order Number

Model Number	Handle Type	Tool Nose	Ordering Number
80-Series (Spring/Beehive Chisel Retainer)	Standard Lever	Hex	80L;HEX
	Safety Lever		80K;HEX
	Offset Backhead (Pistol)		80W;HEX
	Standard Lever	Round	80L;RND
	Safety Lever		80K;RND
	Offset Backhead (Pistol)		80W;RND

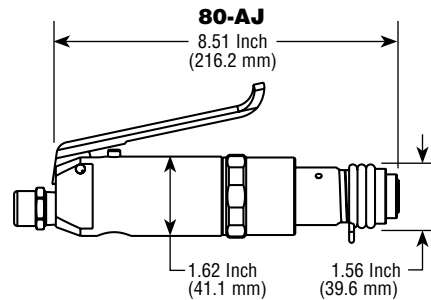

0.63 Inch x 1.44 Inches  
(16 mm x 36.6 mm)



5200



15 cfm (7.1 L/s) Max

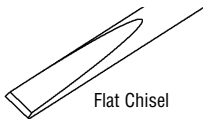

Flat Chisel

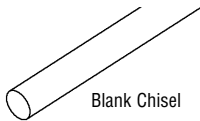

Blank Chisel

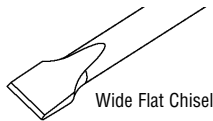

Wide Flat Chisel

### Chisels – 0.401 Round



Description	Cutting Edge	Overall Length	Part Number
Wide Flat Chisel	3/4" (19mm)	11" (279mm)	595003
Flat Chisel	1/2" (12.7mm)	7" (178mm)	595002
Wide Flat Chisel	3/4" (19mm)	7" (178mm)	595001
Wide Flat Chisel	3/4" (19mm)	18" (457mm)	595004
Blank Chisel		7" (178mm)	595005

Other Sizes And Styles Available

### Chisels – 0.371 Hexagon



Description	Cutting Edge	Overall Length	Part Number
Flat Chisel	1/2" (12.7mm)	12" (305mm)	595016

