

Needle Scalers

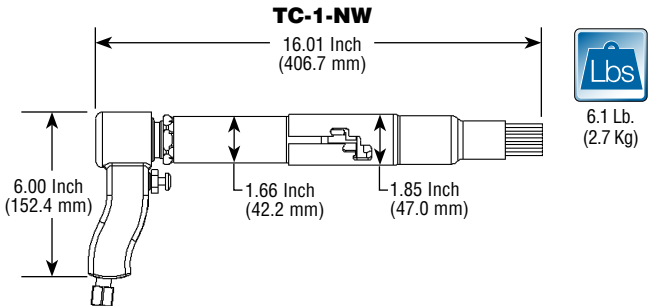

Air Inlet Size: 1/4" NPT
Hose Size Recommendations: 3/8" (10 mm)
Standard Equipment

- Tool • Operating Instructions and Service Manual

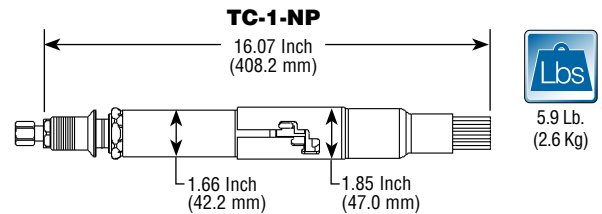
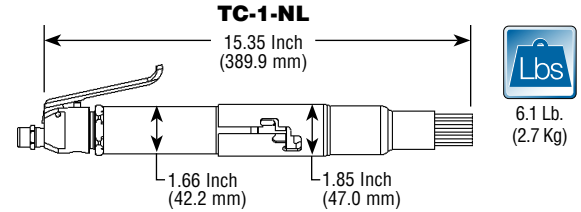

Quick Order Number			
Model Number	Handle Style	Needle Length	Ordering Number
TC-1-N	Lever	5 Inch	TC-1-NL;5
		7 Inch	TC-1-NL;7
	Safety Lever	5 Inch	TC-1-NK;5
		7 Inch	TC-1-NK;7
	Push	5 Inch	TC-1-NP;5
		7 Inch	TC-1-NP;7
	Offset (Pistol)	5 Inch	TC-1-NW;5
		7 Inch	TC-1-NW;7

Top Cat® needle scalers are used to remove weld flux and peen strengthen welds. They can be easily converted to chisel scaler applications. Hardened alloy steel needles come as original equipment.

- 1 Inch x 1.13 Inches (25.4 mm x 29.0 mm)
- 4650
- 20 cfm (9.4 L/s) Max

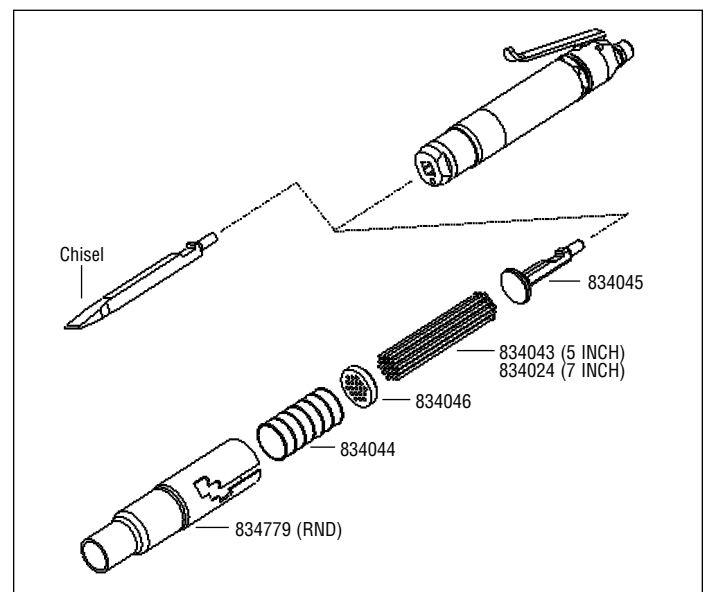

SCALERS