

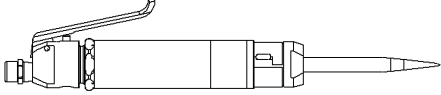



Scalers & Needle Scalers

Section Contents

SCALERS					
Page Number	Model Number	Bore x Stroke	Chisel Style	Description	
85	TC-1	1.0" X 1.1"	1/2 Square 	 Scalers	
86	TC-182	0.98" x 1.1"	1/4 Octagon 		
NEEDLE SCALERS					
Page Number	Model Number	Bore x Stroke	Chisel Style	Description	
87	TC-1-N	1.0" X 1.1"	1/2 Square 	 Needle Scalers	
88	TC-182-N	0.98" x 1.1"	1/4 Octagon 		

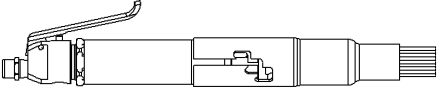
Handles

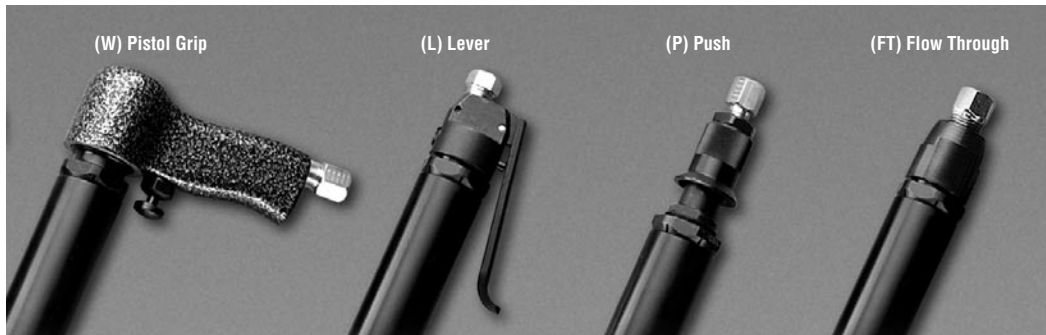

Our scaling tools can be converted for chisel scaling or needle scaling.

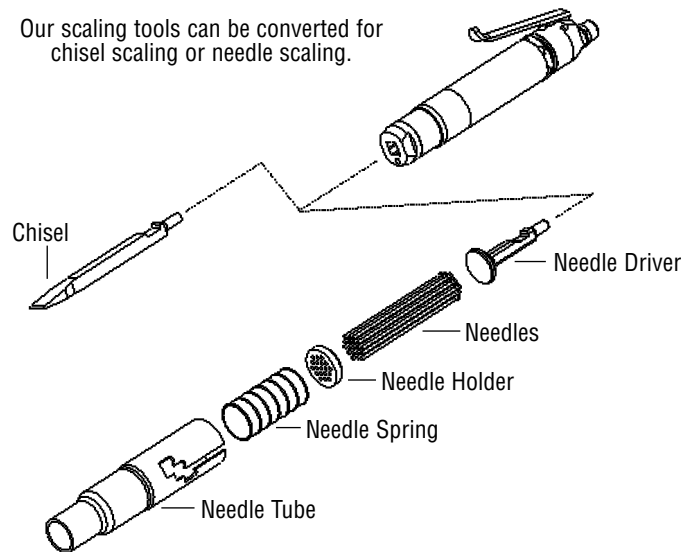

Scalers/Chisels



Air Inlet Size: 1/4" NPT
Hose Size Recommendations: 3/8" (10 mm)
Extra Charge Accessories

- Needle Scaler Attachments • Extended Reach Handle • Safety Lever

Standard Equipment

- Tool • Operating Instructions and Service Manual

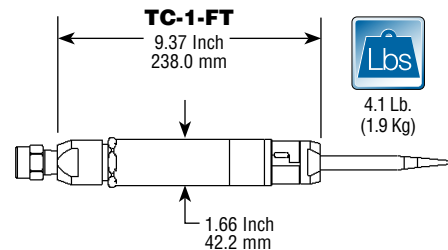
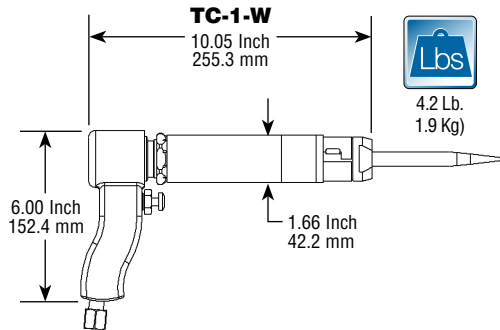
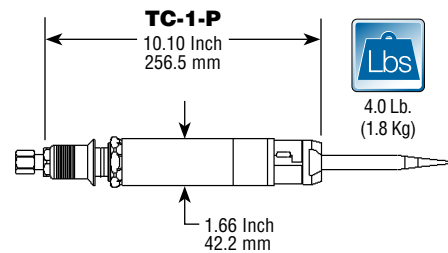
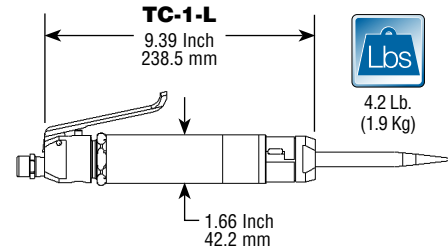

Quick Order Number

Model Number	Handle Style	Ordering Number
TC1	Lever	TC1L
	Safety Lever	TC1K
	Push	TC1P
	Offset (Pistol)	TC1W
	Flow Through	TC1FT
TC1 Floor Scraper	Lever	TC1L;PL48
	Safety Lever	TC1K;PL48

1 Inch x 1.13 Inches (25.4 mm x 29.0 mm)

4650

20 cfm (9.4 L/s) Max

Chisels – 1/2 Inch Square Shank

Description	Cutting Edge	Overall Length	Part Number
Narrow Flat Chisel	3/4" (19mm)	7" (178mm)	839051
Narrow Flat Chisel	3/4" (19mm)	12" (305mm)	839341
Narrow Flat Chisel	3/4" (19mm)	18" (457mm)	839335
Wide Angle Chisel	1 3/8" (34.9mm)	7" (178mm)	839050
Wide Angle Chisel	1 3/8" (34.9mm)	12" (305mm)	839299
Wide Angle Chisel	1 3/8" (34.9mm)	18" (457mm)	839334
Blank Chisel		7" (178mm)	839052
Blank Chisel		12" (305mm)	839053
Blank Chisel		18" (457mm)	839054
Wide Chisel	1 3/8" (34.9mm)	7" (178mm)	839467
Wide Chisel	1 3/8" (34.9mm)	12" (305mm)	839469
2 Inch Wide Scraper	2" (50.8mm)	7" (178mm)	839468

Other Sizes And Styles Available

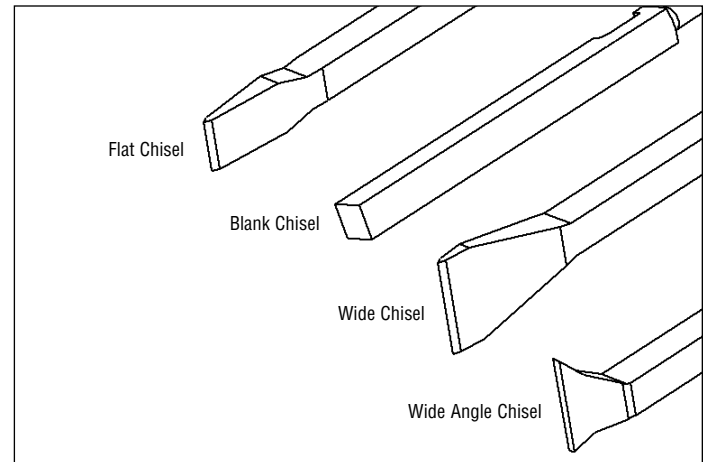

SCALERS

Scalers/Chisels



Air Inlet Size: 1/4" NPT
Hose Size Recommendations: 3/8" (10 mm)
Extra Charge Accessories

- Needle Scaler Attachments • Extended Reach Handle • Safety Lever

Standard Equipment

- Tool • Operating Instructions and Service Manual

Quick Order Number

Model Number	Handle Style	Ordering Number
TC-182	Lever	TC-182-L
	Safety Lever	TC-182-K
	Push	TC-182-P
	Offset (Pistol)	TC-182-W

0.98 Inch x 1.06 Inches (25.0 mm x 27.0 mm)
 4000
 20 cfm (9.4 L/s) Max

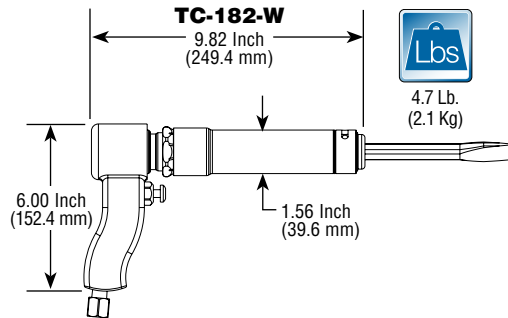
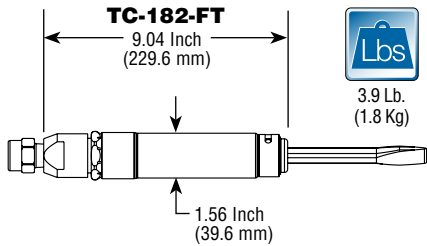
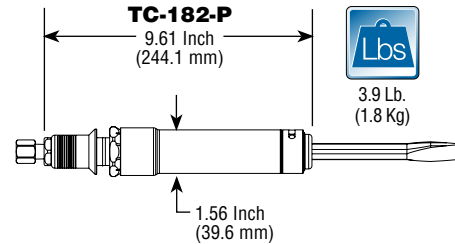
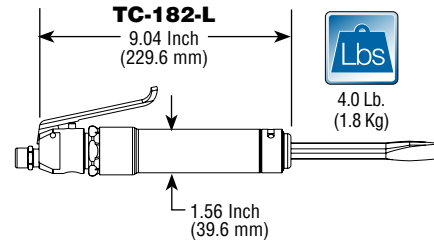

Chisels - 1/4 Inch Octagon

Description	Cutting Edge	Overall Length	Part Number
Narrow Flat Chisel	3/4" (19mm)	7" (17.8cm)	839601
Narrow Flat Chisel	3/4" (19mm)	12" (30.5cm)	839601-12
Blank Chisel		7" (17.8cm)	839605
Blank Chisel		12" (30.5cm)	839605-12
Wide Chisel	1 3/8" (34.9mm)	7" (17.8cm)	839602
Wide Angle Chisel	1 3/8" (34.9mm)	7" (17.8cm)	839604
Wide Angle Chisel	1 3/8" (34.9mm)	12" (30.5cm)	839604-12

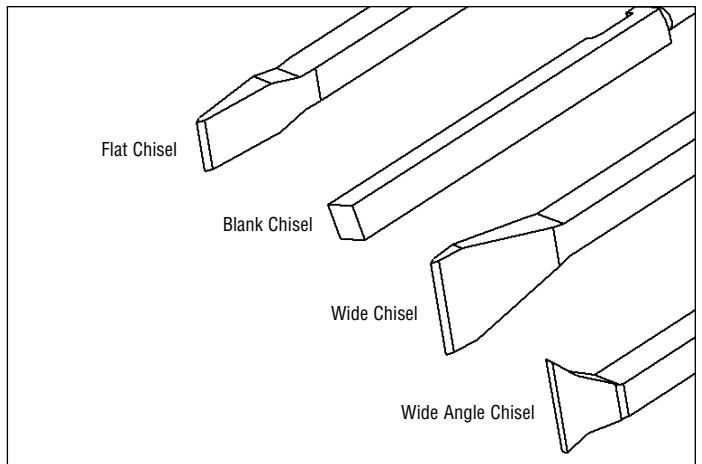

Other Sizes And Styles Available

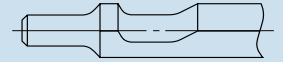

Needle Scalers



Air Inlet Size: 1/4" NPT
Hose Size Recommendations: 3/8" (10 mm)
Standard Equipment

- Tool • Operating Instructions and Service Manual

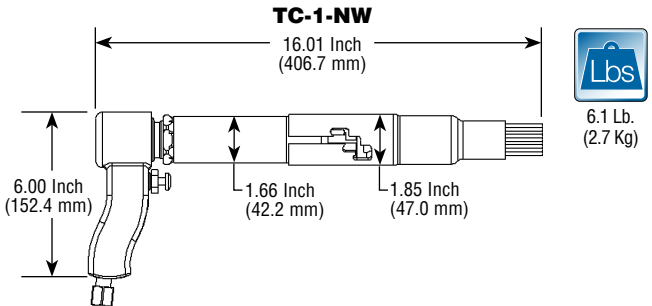
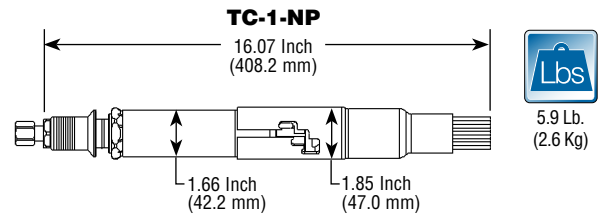
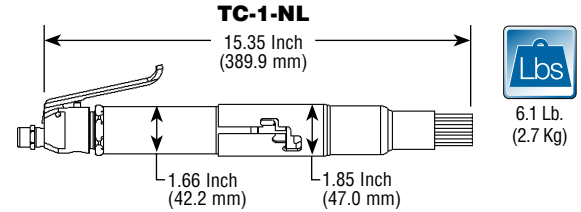

Quick Order Number			
Model Number	Handle Style	Needle Length	Ordering Number
TC-1-N	Lever	5 Inch	TC-1-NL;5
		7 Inch	TC-1-NL;7
	Safety Lever	5 Inch	TC-1-NK;5
		7 Inch	TC-1-NK;7
	Push	5 Inch	TC-1-NP;5
		7 Inch	TC-1-NP;7
	Offset (Pistol)	5 Inch	TC-1-NW;5
		7 Inch	TC-1-NW;7

Top Cat® needle scalers are used to remove weld flux and peen strengthen welds. They can be easily converted to chisel scaler applications. Hardened alloy steel needles come as original equipment.

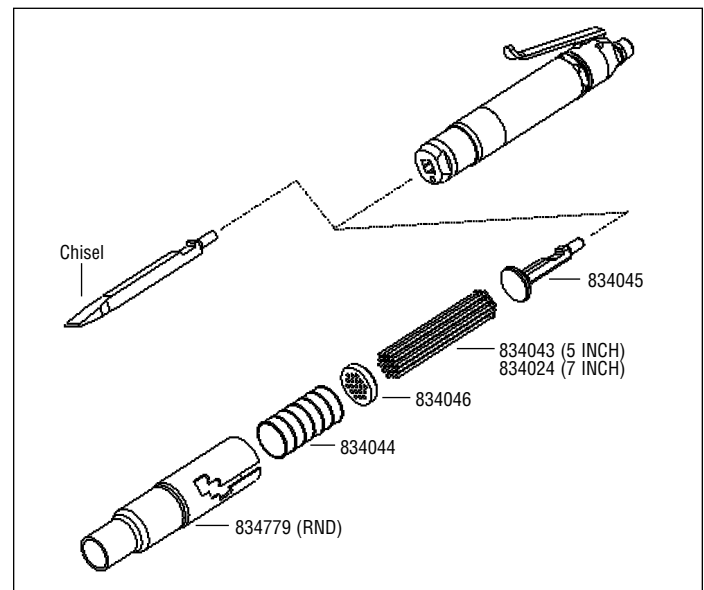

SCALERS

Needle Scalars



Air Inlet Size: 1/4" NPT
Hose Size Recommendations: 3/8" (10 mm)
Standard Equipment

• Tool • Operating Instructions and Service Manual

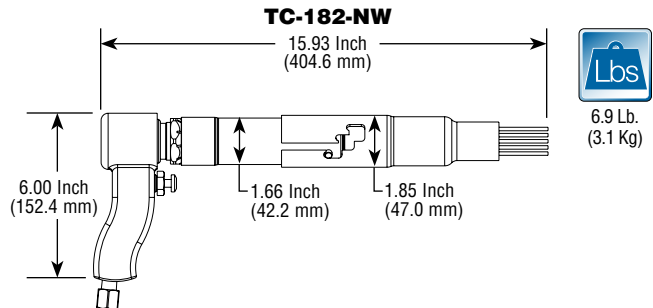
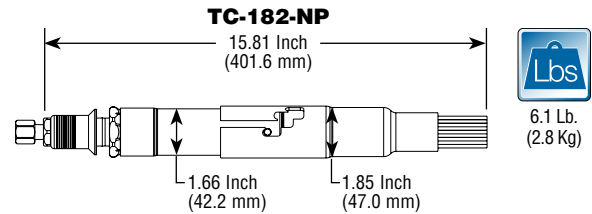
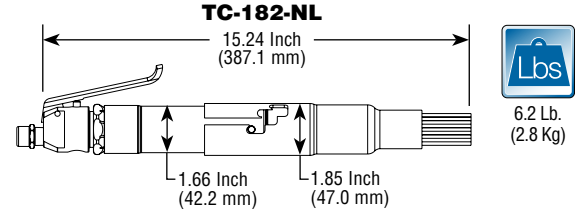

Quick Order Number

Model Number	Handle Style	Needle Length	Ordering Number
TC-182-N	Lever	5 Inch	TC-182-NL;5
		7 Inch	TC-182-NL;7
	Safety Lever	5 Inch	TC-182-NK;5
		7 Inch	TC-182-NK;7
	Push	5 Inch	TC-182-NP;5
		7 Inch	TC-182-NP;7
	Offset (Pistol)	5 Inch	TC-182-NW;5
		7 Inch	TC-182-NW;7

Top Cat® needle scalars are used to remove weld flux and peen strengthen welds. They can be easily converted to chisel scaler applications. Hardened alloy steel needles come as original equipment.



0.98 Inch x 1.06 Inches
(25.0 mm x 27.0 mm)



4000



20 cfm (9.4 L/s) Max

